

PRORIL

60Hz

Designed for light weight, excellent performance, low energy consumption, and easy maintenance, PRORIL submersible handy pumps serve a wide range of pumping applications on utility, construction, industrial, and municipal job sites.

Handy and Residue Pump

SMART VOX 400/750

Handy Pump



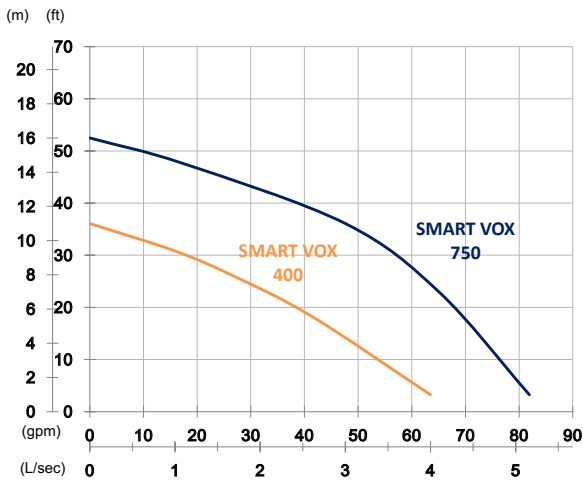

| | SMART VOX 400 | SMART VOX 750 |
|----------------------|--|--|
| OUTPUT | 0.5 HP (0.4 kW) | 1 HP (0.75 kW) |
| OUTLET | 2" (50 mm) | 2" (50 mm) |
| SOLID PASSAGE | 0.3" (7 mm) | 0.3" (7 mm) |
| Weight | 26 lbs/12 kg | 29 lbs/13 kg |
| HEAD | Rated: 26 ft, 8 m Max: 36 ft, 11 m | Rated: 36 ft, 11 m Max: 56 ft, 17 m |
| FLOW | Rated: 26 gpm, 1.6 L/s Max: 62 gpm, 4 L/s | Rated: 48 gpm, 3 L/s Max: 82 gpm, 5.2 L/s |

| | | |
|-------------------------------------|-----------------------|---|
| Pump Type | | Electric Submersible Pumps |
| Motor | Phase | 1-Phase, 3-Phase |
| | Type | Induction Motor |
| | Poles | 2 Pole (3450 rpm) |
| | Insulation | Class F |
| | Protector | Miniature Thermal Protector Circle Thermal Protector |
| | Starter Method | 1-Phase · Capacitor-Run, 3-Phase · D.O.L |
| Lubricant | | Food Grade (ISO VG32) |
| Specs. | Impeller Type | Opened |
| | Shaft Seal | Double Mechanical Seal |
| | | Silicon Carbide VS Ceramic/Carbon |
| | Bearings | C3 Shielded ball bearings |
| | Cable | CSA-Certified PVC Jacketed Cables |
| 33 ft (10 m) or longer upon request | | |
| Materials | Pump Casing | Gray Iron |
| | Impeller | Synthetic Polymers |
| | Motor Frame | Aluminum |
| | Motor Shaft | Stainless Steel |
| | Agitator | Stainless Steel |
| | Strainer | Synthetic Polymers |
| Max. Liquid Temperature | | 40°C (104°F) |
| Max. Submersion Depth | | 20 m (66 ft) |
| pH Range | | pH 5 - pH 8 |

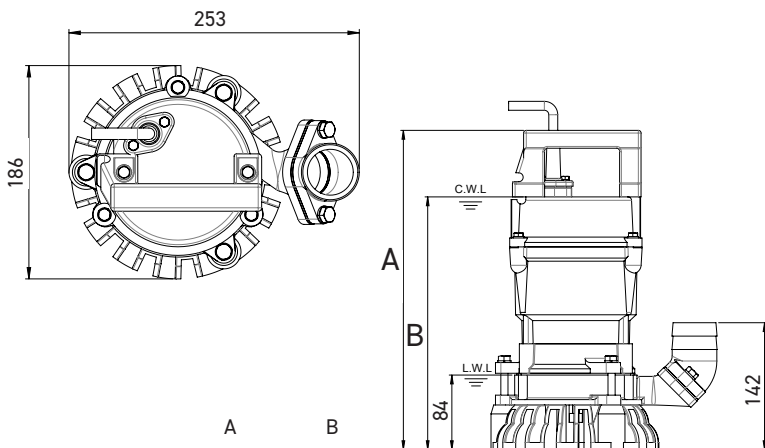

| | A | B |
|---------------|-----|-----|
| SMART VOX 400 | 358 | 283 |
| SMART VOX 750 | 385 | 310 |

unit : mm
C.W.L : Continuous running water level
L.W.L : Lowest running water level